

TABELLA COMPONENTI / COMPONENTS TABLE			
H2Ostop			O0006668
No.	Descrizione / Description	Q.ty	Materiale/Material
1	VALVE RESIN ASS. ARCELK DW H2Ostop 2010	1	-
2	Corrugate Hose DIM24mm H2Ostop Restyling	1	PP
3	FIXING RING	1	POM
4	GUARNIZIONE CON PETALI GASKET WITH PROTRUSIONS	1	EPDM
5	CONNECTOR CEI 63N10 ACQUASTOP	1	PA66
6	FILTRO ASEL SAFETY FILTER	1	POM
7	External Cover.Part1 H2Ostop	1	PP
8	Ext.Cover.Part2 H2Ostop Restyling	1	PP
9	PLASTIC NUT RED H2O STOP RESTYLING	1	PA66 30%GF
10	MANICOTTO hose Electric H2Ostop	1	Alloy 1070A
11	CLH Hose Aquastop	1	LDPE ; LAPRENE
12	FASCETTA ELASTICA HOSE CLAMP	1	STEEL WIRE

NOTES:

- Product conform to EN 60730, EN 61770 and EN 60335 standards
- Coil has an additional protection made by epoxy resin that makes the product IP 67 according to EN 60529
- Nominal Voltage 220/240 V frequency 50/60 Hz
- Solenoid power: 8 VA
- Range of Pressures: 0.2 - 10 bars (0.02 - 1 MPa)
- Service:
Tenv 60° Tmax 25°C 100%ED
Tenv 60° Tmax 90°C AB 3/5 min
- Flow rate regulator: 2.5L/min ±10% (1.5-5Bar +/-15 elsewhere)
- Max torque to fix nut to the tap (manually) is 2 Nm
- Weight 395gramms

NOTE:

- Prodotto conforme alle norme EN60730, EN 61770 and EN 60335
- Bobina protetta con isolamento addizionale di resina epossidica che rende il prodotto IP 67 secondo la EN 60529
- Tensione nominale 220/240 V frequenza 50/60 Hz
- Potenza Bobina: 8 VA
- Campo di pressione 0.2 - 10 bar (0.02 - 1 MPa)
- Servizio:
Tamb 60° Tmax 25°C 100%ED
Tamb 60° Tmax 90°C AB 3/5 min
- Regolatore di portata: 2.5L/min ±10% (1.5-5Bar +/-15 elsewhere)
- Coppia massima di serraggio Ghiera (manuale): 2 Nm
- Peso 395grammi

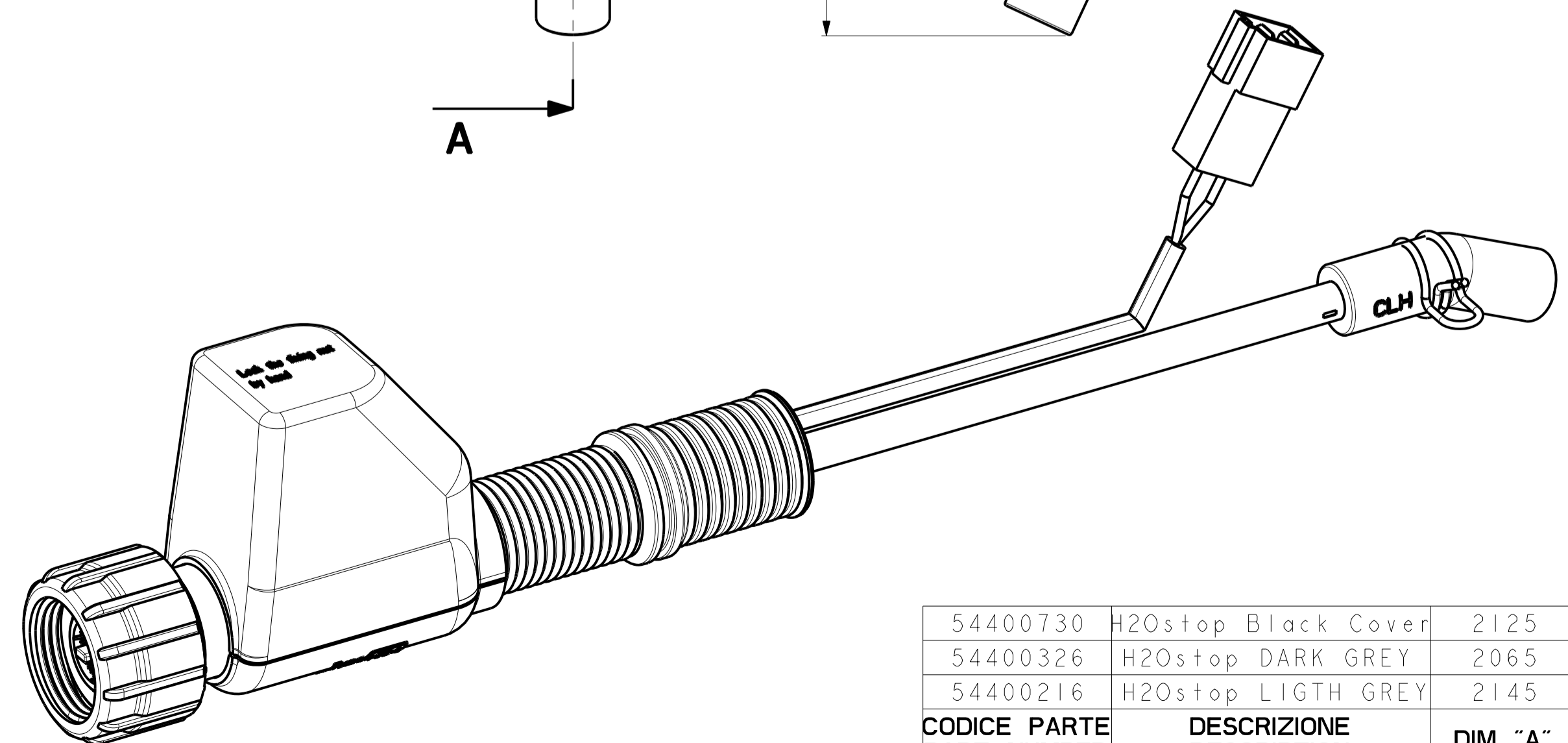

RETURNABLE PACKAGING: 250pcs.

CODICE PARTE / PART NUMBER	DESCRIZIONE / DESCRIPTION	DIM "A"	DIM "B"	COLORE CORRUGATO / CORRUGATE HOSE COLOUR	NOTES
54400730	H2Ostop Black Cover	2125	1940	DARK GREY RAL 7001	with 0.056mm coils - Coil Resistance @20°C = 4100-4550Ω
54400326	H2Ostop DARK GREY	2065	1940	DARK GREY RAL 7001	with 0.056mm coils - Coil Resistance @20°C = 4100-4550Ω
54400216	H2Ostop LIGTH GREY	2145	1940	LIGTH GREY RAL 7032	with 0.056mm coils - Coil Resistance @20°C = 4100-4550Ω

DRN	CHD	APPR.	ISSUED	DATE	BY	TITLE	SCALE	T1
				01/07/20	MORO	ADDED CODE 54400730	H2Ostop	
Code O0006668							A	
Model file name: 54400216 TAB								
Tolerances								
When not shown								

CRITICAL DIMENSIONS

CAD Drawing - Not allowed any hand modifications. Copyright by TSP. Any reproduction without written authorization is forbidden.